

## WAFER TİP KELEBEK VANA FLANŞ BAĞLANTI CİVATA ÖLÇÜLERİ

		PN 6								
DN	B	UZUN CİVATA					KISA CİVATA			
		b	L	L1	Ød	n	L2	Ød	n	
25	28	14	90	75	M10	4				
32	33	14	100	85	M12	4				
40	33	14	100	85	M12	4				
50	43	14	110	95	M12	4				
65	46	14	120	95	M12	4				
80	46	16	130	110	M16	4				
100	52	16	140	120	M16	4				
125	56	18	150	120	M16	8				
150	56	18	150	120	M16	8				
200	60	20	160	130	M16	8				
250	68	22	170	140	M16	12				
300	78	22	190	160	M20	12				
350	78	22	190	160	M20	8	55	M20	8	
400	102	22	220	180	M20	12	60	M20	8	
450	114	24	230	200	M20	12	60	M20	8	
500	127	24	240	210	M20	16	60	M20	8	
600	154	24	280	250	M24	16	65	M24	8	
800	190	24	330	290	M27	20	70	M27	8	

		PN 10								
DN	B	UZUN CİVATA					KISA CİVATA			
		b	L	L1	Ød	n	L2	Ød	n	
16	100	80	M12	4						
16	110	90	M16	4						
16	110	90	M16	4						
18	130	110	M16	4						
18	130	110	M16	4						
20	140	120	M16	8						
20	150	120	M16	8						
22	160	130	M16	8						
22	160	130	M20	8						
24	170	140	M20	8						
26	180	154	M20	12						
26	200	170	M20	12						
26	200	170	M20	12	60	M20	8			
26	230	200	M24	12	65	M24	8			
28	250	210	M24	16	65	M24	8			
28	260	230	M24	16	65	M24	8			
28	300	260	M27	16	70	M27	8			
32	350	310	M30	20	80	M30	8			

		PN 16								
DN	B	UZUN CİVATA					KISA CİVATA			
		b	L	L1	Ød	n	L2	Ød	n	
25	28	16	100	80	M12	4				
32	33	16	110	90	M16	4				
40	33	16	110	90	M16	4				
50	43	18	130	110	M16	4				
65	46	18	130	110	M16	4				
80	46	20	140	120	M16	8				
100	52	20	150	120	M16	8				
125	56	22	160	130	M16	8				
150	56	22	160	130	M20	8				
200	60	24	170	140	M20	12				
250	68	26	190	160	M24	12				
300	78	28	210	180	M24	12				
350	78	30	210	180	M24	12	65	M24	8	
400	102	32	250	210	M27	12	70	M27	8	
450	114	34	260	230	M27	16	70	M27	8	
500	127	34	280	240	M30	16	70	M30	8	
600	154	36	320	280	M33	16	75	M33	8	
800	190	38	380	330	M36	20	85	M36	8	

		ANSI 150								
DN	B	UZUN CİVATA					KISA CİVATA			
		b	L1	d		n	L2	d		n
15	90	1/2 "	13 UNC			4				
16	90	1/2 "	13 UNC			4				
18	100	1/2 "	13 UNC			4				
19	110	5/8 "	11 UNC			4				
22	120	5/8 "	11 UNC			4				
24	130	5/8 "	11 UNC			4				
24	130	5/8 "	11 UNC			8				
25	140	3/4 "	10 UNC			8				
25	140	3/4 "	10 UNC			8				
29	160	3/4 "	10 UNC			8				
30	170	7/8 "	9 UNC			12				
32	190	7/8 "	9 UNC			12				
35	200	1"	8 UNC			8	70	1"	8 UNC	8
37	220	1"	8 UNC			12	75	1"	8 UNC	8
40	250	1 1/8"	8 UNC			12	80	1 1/8"	8 UN *1	8
43	270	1 1/8"	8 UNC			16	80	1 1/8"	8 UN *1	8
48	310	1 1/4"	8 UNC			16	80	1 1/4"	8 UN *1	8
52	370	1 1/2"	8 UNC *2			24	95	1 1/2"	8 UN *2	8

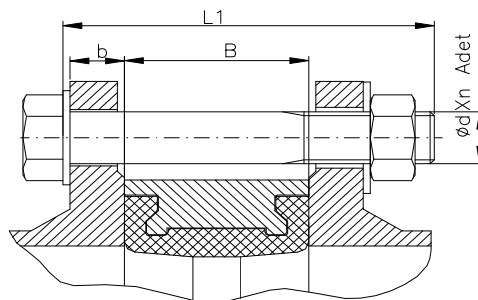
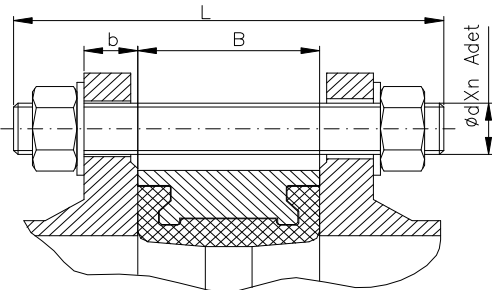

## LUG TİP KELEBEK VANA FLANŞ BAĞLANTI CİVATA ÖLÇÜLERİ

DN	B	PN 6			
		CİVATA			
		b	L2	Ød	n
25	28	14	30	M10	8
32	33	14	30	M12	8
40	33	14	30	M12	8
50	43	14	35	M12	8
65	46	14	35	M12	8
80	46	16	40	M16	8
100	52	16	40	M16	8
125	56	18	45	M16	16
150	56	18	45	M16	16
200	60	20	50	M16	16
250	68	22	55	M16	24
300	78	22	55	M20	24
350	78	22	55	M20	24
400	102	22	60	M20	32
450	114	24	60	M20	32
500	127	24	60	M20	40
600	154	24	65	M24	40
800	190	24	70	M27	48

PN 10			
CİVATA			
b	L2	Ød	n
16	30	M12	8
16	30	M16	8
16	30	M16	8
18	40	M16	8
18	40	M16	8
20	40	M16	16
20	45	M16	16
22	50	M16	16
22	50	M20	16
24	55	M20	16
26	60	M20	24
26	60	M20	24
26	60	M20	32
26	65	M24	32
28	65	M24	40
28	65	M24	40
28	70	M27	40
32	80	M30	48

ANSI 150			
CİVATA			
b	L2	d	n
15	30	1/2 " 13 UNC	8
16	30	1/2 " 13 UNC	8
18	30	1/2 " 13 UNC	8
19	40	5/8 " 11 UNC	8
22	45	5/8 " 11 UNC	8
24	45	5/8 " 11 UNC	8
24	50	5/8 " 11 UNC	16
25	50	3/4 " 10 UNC	16
25	50	3/4 " 10 UNC	16
29	60	3/4 " 10 UNC	16
30	65	7/8 " 9 UNC	24
32	70	7/8 " 9 UNC	24
35	70	1" 8 UNC	24
37	75	1" 8 UNC	32
40	80	1 1/8" 8 UN *1	32
43	80	1 1/8" 8 UN *1	40
48	80	1 1/4" 8 UN *1	40
52	95	1 1/2" 8 UN *2	56

DN	B	PN 16			
		CİVATA			
		b	L2	Ød	n
25	28	16	30	M12	8
32	33	16	30	M16	8
40	33	16	30	M16	8
50	43	18	40	M16	8
65	46	18	40	M16	8
80	46	20	40	M16	16
100	52	20	45	M16	16
125	56	22	50	M16	16
150	56	22	50	M20	16
200	60	24	55	M20	24
250	68	26	60	M24	24
300	78	28	65	M24	24
350	78	30	65	M24	32
400	102	32	70	M27	32
450	114	34	70	M27	40
500	127	34	70	M30	40
600	154	36	75	M33	40
800	190	38	85	M36	48

NOT : \* 1 EN 593 Standartına göre vana gövde dış bağlantı civatalarının 1" ten büyük olanlarını 8 UN vida dişi olarak uygulanır

\* 2 MSS CLASS 150

L veya L1 Ölçülerinin tercihi kullanıcıya aittir

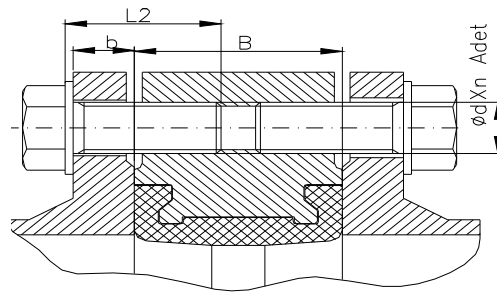

## KELEBEK VANA FLANŞ BAĞLANTISI CİVATA SIKMA TORKLARI

KELEBEK VANA CİVATALARI SIKMA TORKLARI														
DN	50	65	80	100	125	150	200	250	300	350	400	450	500	600
TORK Nm	33	38	42	45	48	62	72	88	110	120	130	150	160	210

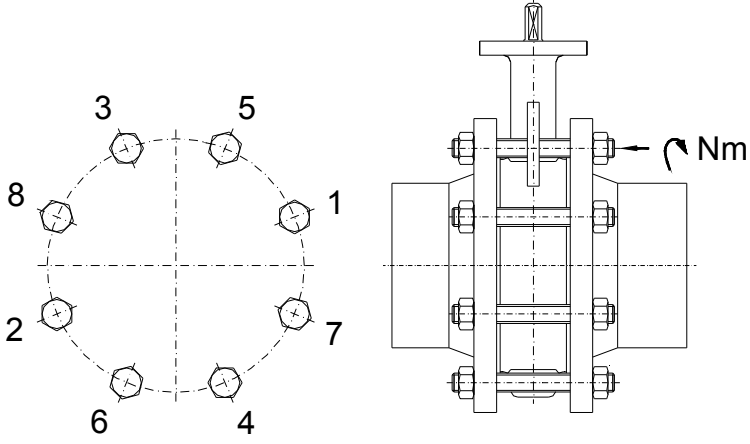

DN 25 - 300 WAFER

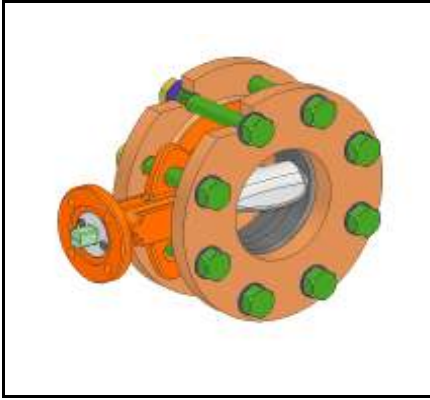

DN 350 - 800 WAFER

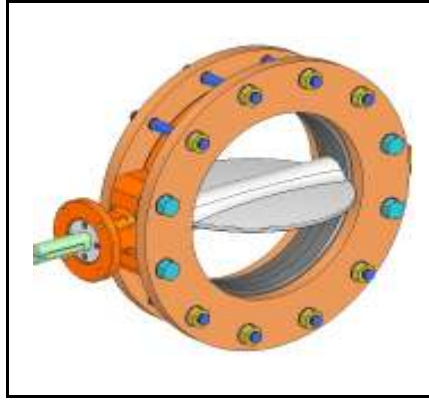

DN 25 - 800 LUG

